



Franklin Pump Systems

S - J Series Pump OWNER'S MANUAL

Before Installation be sure to read all the instructions and warnings carefully. Refer to the product data plates for additional operating instruction and specifications.

INSPECTION

Examine the equipment when received. Notify your dealer or carrier of any damage or missing parts. Verify that the equipment is of size and model specified.

READ AND FOLLOW SAFETY INSTRUCTIONS

 This is the safety alert symbol. When you see this symbol on your pump or in this manual, look for one of the following signal words and be alert to the potential for personal injury:

DANGER warns about hazards that will cause serious personal injury, death or major property damage if ignored.

WARNING warns about hazards that **can** cause serious personal injury, death or major property damage if ignored.

CAUTION warns about hazards that **will** or **can** cause minor personal injury or major property damage if ignored.

The label **NOTICE** indicates special instructions, which are important but not related to hazards.

WARNING



Hazardous voltage. Can shock, burn, or cause death.

Ground pump before connecting to power supply. Disconnect power before working on pump, motor or tank.

Carefully read and follow all safety instructions in this manual and on pump.

Keep safety labels in good condition.

Replace missing or damaged safety labels.

 **Wire motor for correct voltage. See "Electrical" section of this manual and motor nameplate.**

 **Ground motor before connecting to power supply.**

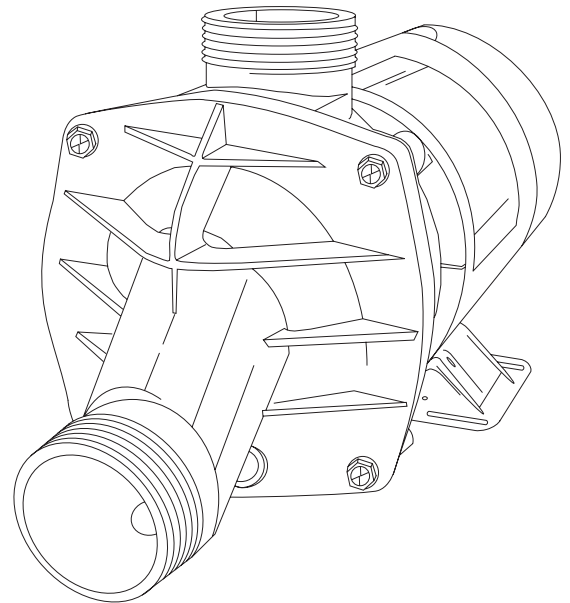
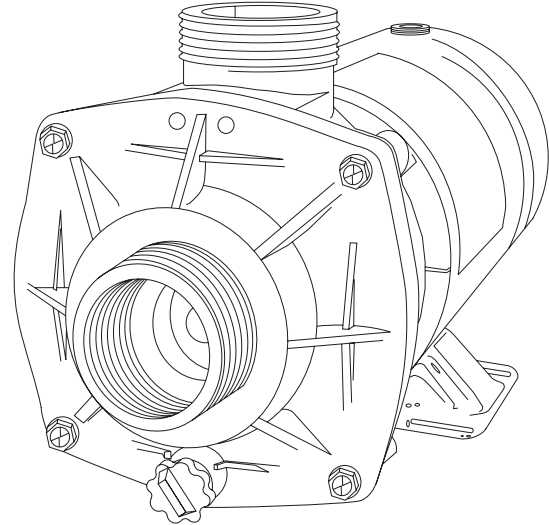

 **Meet National Electrical Code, Canadian Electrical Code, and local codes for all wiring.**

 **Follow wiring instructions in this manual when connecting motor to power lines.**

INSTALLATION LOCATION

All S & J Series pumps are designed for flooded suction (all suction fittings and suction piping are below water level) and will not self-prime.

GENERAL PLUMBING

FOR SOLVENT WELD CONNECTIONS

Rigid or flexible PVC pipe can be used. Pipe ends should be clean and free of any flash caused by the cutting operation. Be sure that the proper adhesive is used on the type of pipe specified.

Recommended Adhesives- These are examples only and are not intended to restrict brands.

PVC-PVC JOINT	PVC-ABS JOINT
Uni-weld Pool-Tite 2000	Uni-weld Pool-Tite 2000
Suregard Flex 20	Suregard Weld-all No. 5
IPS Weld-on 705	IPS Weld-on 794

NOTE: A Primer will assure that adhesives joints are superior. Sureguard P-3000 has a purple tracer to qualify in areas where codes specify a primer must be used.

CAUTION- We recommend that you consider climatic conditions when applying adhesives. Certain atmospheric situations, such as high moisture content, make the adhesive action of certain glues less effective. Check the manufacturer's instructions.

FOR THREADED CONNECTIONS

Use only Teflon tape or equivalent on threaded plumbing connections. Other pipe compounds may damage threads. We do not recommend the use of silicone or petroleum based compounds.

DO NOT OVER TIGHTEN! HAND TIGHTEN PLUS 1/2 TURN IS SUFFICIENT.

PUMP PLUMBING

All S & J Series pumps are union connected allowing quick and easy service without disturbing the plumbing. Two different plumbing configurations are available offering 1-1/2" suction connection and either 1-1/2" discharge or 1" tee discharge. These union packages must be ordered separately. Avoid using a suction pipe smaller than pump connection.

To maximize the 100% drain feature, keep the piping as straight and short as possible, and slope horizontal runs so water drains away from pump. The suction line must be installed at an elevation below the water level when the tub is filled to guarantee flooded suction.

ELECTRICAL DATA

Refer to information on motor nameplate for electrical service data. All motors should have fused disconnect switch or circuit breaker. Be sure wire size is sufficient for HP and distance from power source. Wiring should be done in accordance with applicable codes by competent electrician. We recommend the installation of a ground fault circuit interrupter for maximum safety.

PUMP START UP

Fill tub to desired level making sure that suction fittings and jets are below water level. Start pump and open all suction and discharge line valves.

After about 10 minutes of operation, check the return fittings for air bubbles. A continuous flow of air indicates leaks in the suction line. Locate and correct any leaks immediately.

CAUTION- Do not operate pump with closed suction or discharge valves.

TWO-SPEED PUMPS

Two-speed models are recommended in a swimming pool when high speed is needed for maximum filtration at peak periods and whenever turbidity levels are high. At other times, switch to low speed. For backwashing and vacuuming, high speed is required.

In spa and hot tubs, use high speed to attain full performance in the hydro-therapy mode. At other times, such as filter/heat cycle mode, use low speed. Low speed provides sufficient flow to activate most spa heaters and provides sufficient flow for filtration.

In jetted tubs, use high speed to attain full performance in the hydro-therapy mode and use low speed for desired low flow conditions.

NOTE: Two-speed pumps must be in high speed mode to prime.

PUMP MAINTENANCE

1. Motors are self-lubricating-- no lubrication is required.
2. Clean Hair & Lint Strainer if you have a pump with strainer body.
3. Visually inspect motor for blockage of air vents on motor shell. Remove any debris after shutting off breaker.
4. Shaft seals may become worn and must be replaced if leakage is observed.

SERVICE AND REPAIR PARTS

Refer all service to your local dealer as his knowledge of your equipment makes him the best qualified source of information. Order all repair parts through your dealer. Give the following information when ordering repair parts.

1. Unit nameplate data
2. Description of part

TROUBLESHOOTING

MOTOR DOES NOT START

1. Disconnect switch or circuit breaker in OFF position.
2. Fuses blown or thermal overload open.
3. Locked motor shaft.
4. Motor windings burned out.
5. Defective starting switch inside single-phase motor.
6. Disconnected or defective wiring.
7. Low voltage.

MOTOR DOES NOT REACH FULL SPEED

1. Low voltage.
2. 2 speed model set on low speed.
3. Motor windings connect for wrong voltage on dual voltage model.

MOTOR OVERHEATS (Protector trips)

1. Low voltage.
2. Motor windings connected for wrong voltage on dual voltage model.
3. Inadequate ventilation.

PUMP DELIVERS NO WATER

1. Pump is not primed.
2. Closed valve in suction or discharge line.
3. Leakage of air into suction line.
4. Impeller Clogged.

LOW PUMP CAPACITY

1. Valve in suction or discharge line partly closed.
2. Suction or discharge line partly plugged.
3. Suction or discharge line too small.
4. Pump running at reduced speed (see above)
5. Impeller clogged.

LOW PUMP PRESSURE

1. Pump running at reduced speed (see motor)
2. Discharge valve or inlet fittings open too wide.

HIGH PUMP PRESSURE

1. Discharge valve or inlet fittings closed too much.
2. Return lines too small.

NOISY PUMP AND MOTOR

1. Worn motor bearings.
2. Valve in suction line partly closed.
3. Suction line partly plugged.
4. Pump not supported properly.

LEAKAGE OR WATER AT SHAFT

1. Shaft seal requires replacement.

AIR BUBBLES AT INLET FITTINGS

1. Leakage of air into suction line at connections or valve system.
2. Restriction in suction line.

LEAKING UNIONS

1. O-ring missing or damaged.
2. Plumbing in bind.
3. Insufficient tightening.

NOTE: If the recommendations in the Troubleshooting portion of this manual do not solve your particular problem(s), please contact your local dealer for service.

PARTS FOR MODEL J, JCM, S, and SKM

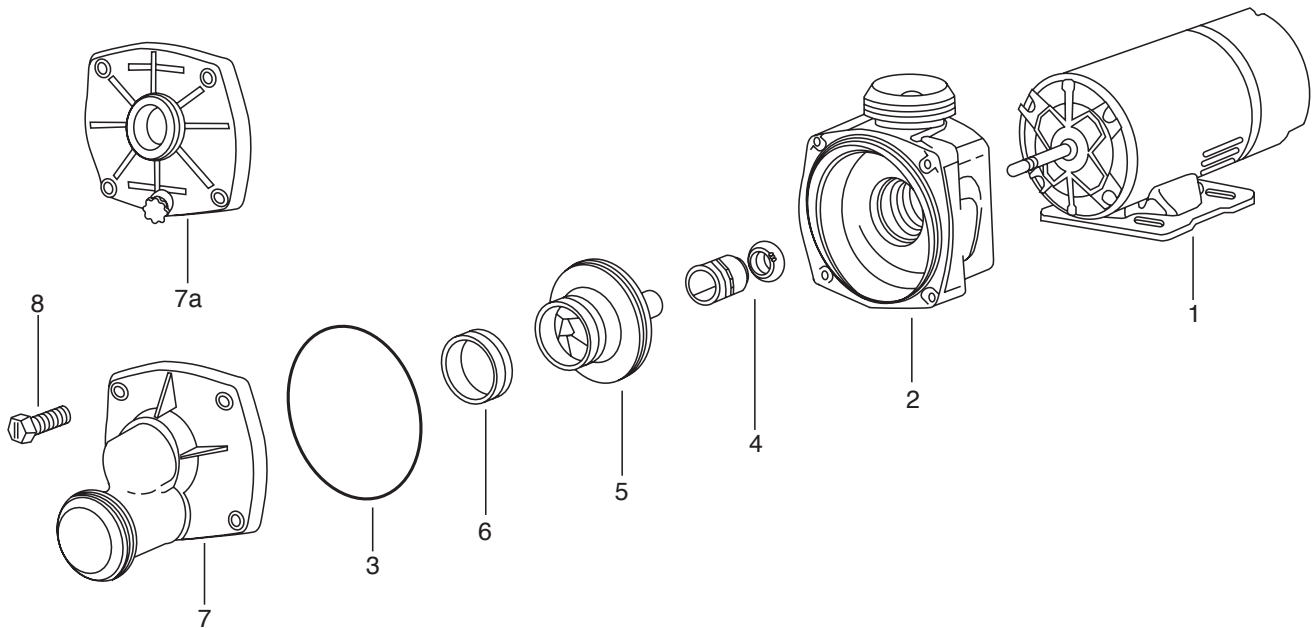

Figure No.	Part No.	Description
1	9010-1197-R	Motor 3/4HP 115/1/60 48Y Frame
	9010-1247-R	Motor 1HP 115/1/60 48Y Frame
	9010-0710-R	Motor 1-1/2HP 115/1/60 48Y Frame
2	02-1308-05-RKIT	J Bracket Kit (incl. #7 3-10 butt & #8 1/4-14 x 1-1/8 fasteners)
	02-1309-04-R	JCM & SKM Bracket (eff. 2/1/94) 1/4-14 Thrd, 2-1/2 butt
	02-1613-05-R	JCM & SKM Bracket (eff. prior 2/1/94) 1/4-20 Thrd, 2-1/2 butt
3	47-0357-46-R	O-ring 5-1/2 x 5-7/8 x 3/16
4	10-0002-06-R	5/8 Mechanical Seal
5	05-3862-06-R	Impeller S7J, S7K #11343 3.45D
	05-3863-05-R	Impeller S1J, S1K #11343 3.73D
	05-3864-04-R	Impeller S15J, S15K #11343 4.10D
	05-3865-03-R	Impeller S2J, S2K #11304 4.22D
6	10-1462-07-R	Eye Seal
7	03-0651-09-R	J Flange 3-10 butt
	03-0854-04-R	JCM Flange 2-1/21-8 butt
7a	11-1517-01-R	SKM Flange 2-1/2" butt with 1/4" plug 31160906R
8	14-1266-35-R	Fastener 1/4-20x3/4 4 required, Eff, for units prior to 2/1/94 "J" model
	14-4339-08-R	J, JCM and SKM Fastener 1/4-14 x 1-1/8

U.S. LIMITED WARRANTY*

Franklin Pump Systems, Inc.

Franklin Pump Systems, Inc. warrants its new products to be free of defects in material and workmanship for a period of 1 year from date of installation or 2 years from date of manufacture, whichever comes first, WHEN installed in a domestic water systems application and pumping potable water only. Warranty does not cover applications pumping saltwater or other corrosive liquids. Consult and adhere to local codes for all applications. Franklin Pump Systems, Inc. also provides additional warranty coverage on specific products as specified herein.

Franklin Pump System's warranty obligation with regard to equipment not of its own manufacture is limited to the warranty actually extended to Franklin Pump System by its suppliers.

This warranty extends only to the original retail purchaser and only during the time in which the original retail purchaser occupies the site where the product was originally installed.

Requests for service under this warranty shall be made by contacting the installing Franklin Pump System dealer (point of purchase) as soon as possible after the discovery of any alleged defect. Franklin Pump System will subsequently take corrective action as promptly as reasonably possible.

Franklin Pump System at its discretion may replace or repair any product that fails under this warranty after inspection by an authorized company representative or after Franklin Pump System has received the product at our factory. Replacement or repair cannot be made until after the product is inspected. All charges or expenses for freight to and from the factory, removal and reinstallation of the product, or installation of a replacement product are the responsibility of the purchaser.

THIS WARRANTY SUPERSEDES ANY WARRANTY NOT DATED OR BEARING AN EARLIER DATE. ANY IMPLIED WARRANTIES WHICH THE PURCHASER MAY HAVE, INCLUDING MERCHANT ABILITY AND FITNESS FOR A PARTICULAR PURPOSE, SHALL NOT EXTEND BEYOND THE APPLICABLE WARRANTY PERIOD. Some states do not allow limitations on how long an implied warranty lasts, so the above limitation may not apply to you. IN NO EVENT SHALL FRANKLIN PUMP SYSTEM BE LIABLE FOR INCIDENTAL OR CONSEQUENTIAL DAMAGES. Some states do not allow the exclusion or limitation of incidental or consequential damages, so the above may not apply to you.

This warranty does not apply to any product which has been subjected to negligence, alteration, accident, abuse, misuse, improper installation, vandalism, civil disturbances, or acts of God. The only warranties authorized by Franklin Pump System are those set forth herein. Franklin Pump System does not authorize other persons to extend any warranties with respect to its products, nor will Franklin Pump System assume liability for any unauthorized warranties made in connection with the sale of its products.

THIS WARRANTY GIVES YOU SPECIFIC LEGAL RIGHTS, AND YOU MAY ALSO HAVE OTHER RIGHTS WHICH MAY VARY FROM STATE TO STATE.

* Contact Franklin Pump Systems, Inc. Export Division for International Warranty.



Franklin Pump Systems

12401 Interstate 30 • P.O. Box 8903
Little Rock, AR 72219

